

FITNESS	PISTON	LEST	RICARICA	R-PRO	INOX	STREET WORKOUT
STATION FUSION	SALUTE	COMBATTENTE	NINJA	FIGHT CLUB	SENIOR	ARREDO URBANO

CHEST PRESS RPRO



RESISTENZA MAGNETICA REGOLABILE !

Vero e proprio attrezzo professionale da allenamento, Il Chest press R-PRO permette di rinforzare la parte superiore del corpo.

Con lo schermo LCD a colori è possibile impostare la difficoltà e ottenere informazioni preziose per un allenamento ottimale (durata, calorie bruciate, ripetizioni).

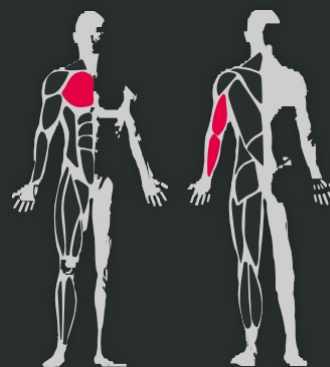

DIMENSIONI

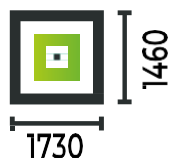

 **COACHING**
PERSONALIZZATO

DISPONIBILE SUR
Google play



Télécharger dans
l'App Store



10 GARANZIA*
ANNI

SCHERMO LCD & BLUETOOTH

Totalmente autonomo! Il display di controllo si attiva tramite resistenza magnetica quando l'attrezzo è in uso. Progettato per l'uso all'aperto, offre la possibilità di impostare programmi di allenamento e fornisce informazioni preziose sull'allenamento che si sta svolgendo (durata, calorie bruciate, ripetizioni).



I COMPONENTI

- 1** Panca in acciaio zincato verniciato a polvere con seduta in PEHD.
- 2** Maniglie antiscivolo saldate.
- 3** Piano di allenamento sull'attrezzo, tradotto in 4 lingue per 4 profili sportivi.
- 4** Fissaggio su base standard, copertura di fissaggio in acciaio.

Su che tipo di suolo può essere installato?

Cemento, rivestito e stabilizzato



Terreno soffice



Terreno erboso



Truciolli di legno*



Ghiaia*



Sabbia*



Pavimento soffice*



Lastra ammortizzante*



Erba sintetica*

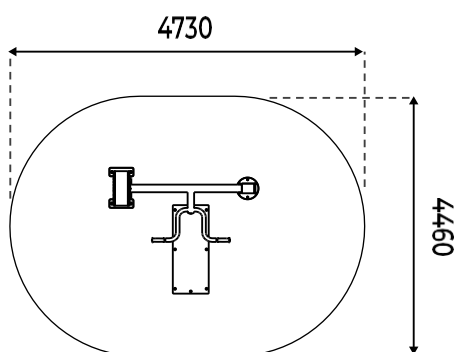

*secondo la norma EN 16630

ZONA D'IMPATTO

SIGILLATURA FONDAZIONE
