

FITNESS	<b>PISTON</b>	LEST	RICARICA	R-PRO	INOX	STREET WORKOUT
STATION FUSION	SALUTE	COMBATTENTE	NINJA	FIGHT CLUB	SENIOR	ARREDO URBANO

## CRUNCH MACHINE



Scansiona



### UNA VERA MACCHINA DA ALLENAMENTO!

La Crunch Machine è la nostra gamma di attrezzature per pistoncini progettata per far lavorare i muscoli addominali.

Seduti sul sedile, afferrate le maniglie e fate rotolare la parte bassa della schiena cercando di mantenere la pancia in dentro.

Le mani accompagnano il movimento con l'aiuto delle impugnature.

Regolare la manopola per aumentare o diminuire la resistenza.

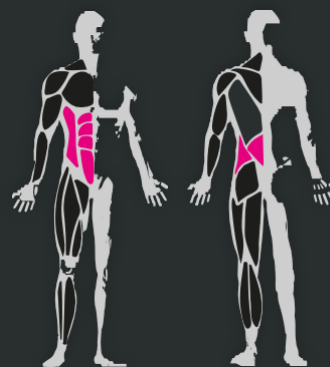

#### DIMENSIONI

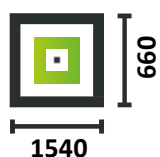

COACHING  
PERSONALIZZATO

DISPONIBILE SU  
Google play

Télécharger dans  
l'App Store



**10** GARANZIA\*  
**ANNI**



## I COMPONENTI

**1** Attrezzo realizzato interamente in acciaio zincato e successivamente verniciato a polvere.

**2** Il piano di formazione, fissato al telaio e tradotto in 4 lingue per 4 profili sportivi.

**3** Pistone idraulico in acciaio inox con resistenza regolabile (8 livelli).

**4** Montaggio su plinto con sgabello di ancoraggio. Copertura in acciaio.

Su che tipo di suolo può essere installato?

Cemento, rivestito e stabilizzato



Terreno soffice



Terreno erboso



Truciolini di legno\*



Ghiaia\*



Sabbia\*



Pavimentazione soffice\*



Lastra ammortizzante\*



Erba sintetica\*



\*secondo la norma EN 16630

### ZONA D'IMPATTO

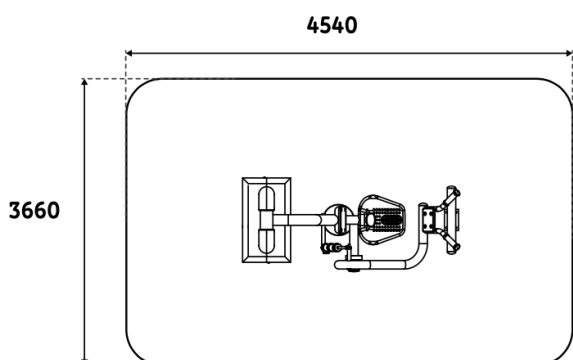

### SIGILLATURA FONDAZIONE

Sgabello di ancoraggio

